

Low Capacitance TVS Diode

- ESD / transient protection of high-speed data lines in 3.3 / 5 / 12 V applications according to:
IEC61000-4-2 (ESD): ±16 kV (air) ±14 kV (contact)
IEC61000-4-4 (EFT): 40 A (5 / 50 ns))
- Extremely small form factor down to 0.62 x 0.32 x 0.31 mm³
- Max. working voltage: -8 / +14 V
- Very low reverse current < 1 nA typ.
- Very low series inductance down to 0.2 nH typ.
- Low capacitance of 4 pF typ.
- Pb-free (RoHS compliant) package
- Qualified according AEC Q101

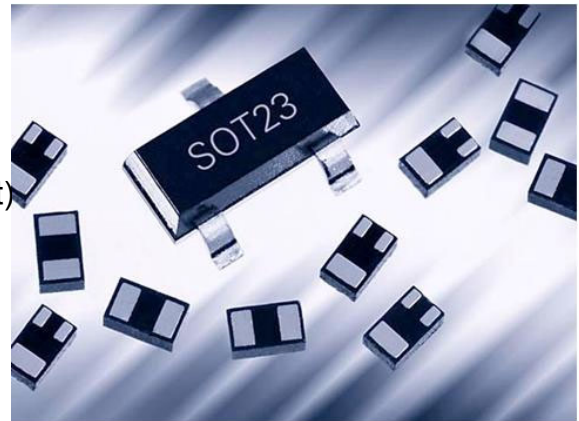

Applications

- USB 2.0, 10/100 Ethernet, Firewire, DVI
- Mobile communication
- Consumer products (STB, MP3, DVD, DSC...)
- LCD displays, camera
- Notebooks and desktop computers, peripherals



ESD8V0R1B-02LS
ESD8V0R1B-02LRH

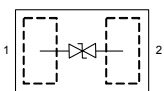

Type	Package	Configuration	Marking
ESD8V0R1B-02LRH	TSLP-2-7	1 line, bi-directional	E
ESD8V0R1B-02LS	TSSLP-2-1	1 line, bi-directional	E

Maximum Ratings at $T_A = 25^\circ\text{C}$, unless otherwise specified

Parameter	Symbol	Value	Unit
ESD discharge ¹⁾ air contact	V_{ESD}	16 14	kV
Peak pulse current ($t_p = 8 / 20 \mu\text{s}$) ²⁾	I_{pp}	1	A
Operating temperature range	T_{op}	-55...150	°C
Storage temperature	T_{stg}	-65...150	

Electrical Characteristics at $T_A = 25^\circ\text{C}$, unless otherwise specified

Parameter	Symbol	Values			Unit
		min.	typ.	max.	

Characteristics

Reverse working voltage, from pin 2 to 1	V_{RWM}	-8	-	14	V
Breakdown voltage	$V_{(\text{BR})}$				
$I_{(\text{BR})} = 1 \text{ mA}$, from pin 2 to 1		14.5	17	20	
$I_{(\text{BR})} = 1 \text{ mA}$, from pin 1 to 2		8.5	11	14	
Reverse current $V_R = 3.3 \text{ V}$	I_R	-	<1	50	nA
Clamping voltage	V_{CL}				V
$I_{\text{PP}} = 1 \text{ A}$, $t_p = 8/20 \mu\text{s}$, from pin 2 to 1 ²⁾		-	23	28	
$I_{\text{PP}} = 1 \text{ A}$, $t_p = 8/20 \mu\text{s}$, from pin1 to 2 ²⁾		-	17	22	
Line capacitance $V_R = 0 \text{ V}$, $f = 1 \text{ MHz}$	C_T	-	4	7	pF
Series inductance	L_S				nH
ESD8V0R1B-02LS		-	0.2	-	
ESD8V0R1B-02LRH		-	0.4	-	

¹⁾ V_{ESD} according to IEC61000-4-2

²⁾ I_{pp} according to IEC61000-4-5

Reverse current $I_R = f(V_R)$

$T_A =$ Parameter

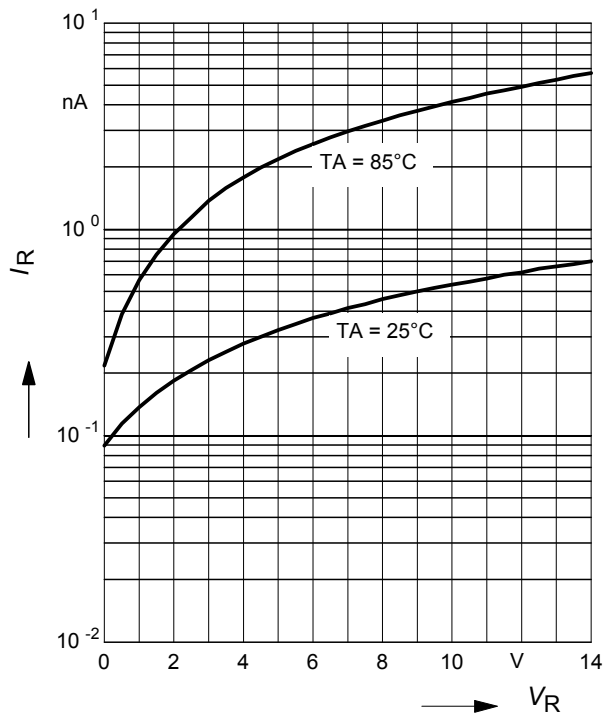

Diode capacitance $C_T = f(V_R)$

$f = 1\text{MHz}$

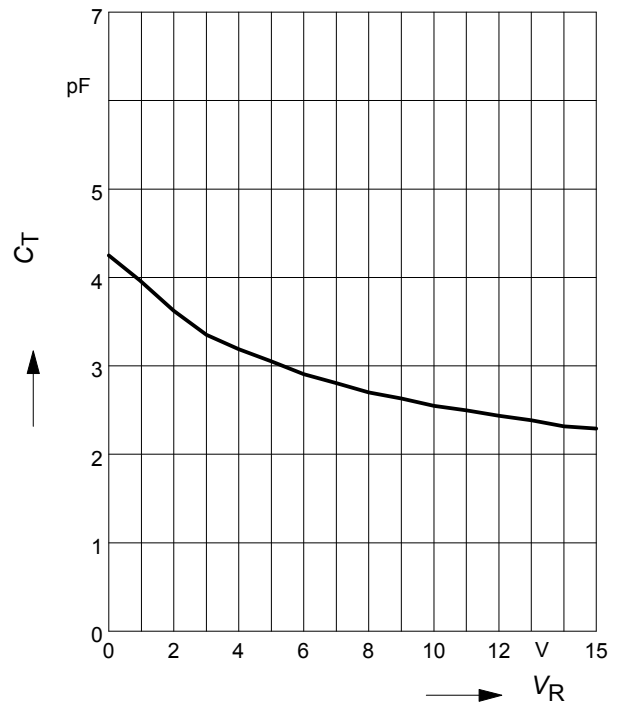

Application example ESD8V0R1B...

1 line, bi-directional

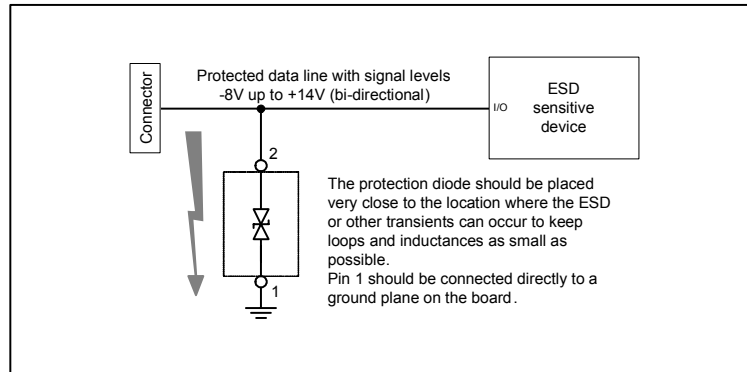

Package Outline

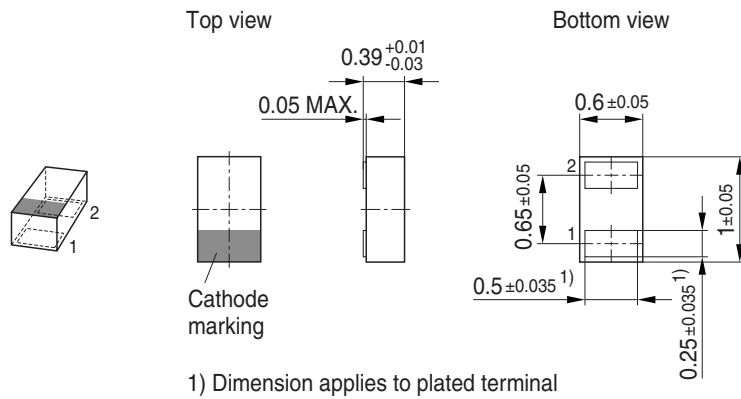

Foot Print

For board assembly information please refer to Infineon website "Packages"

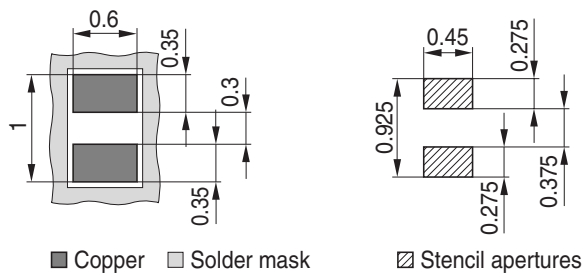

Marking Layout (Example)

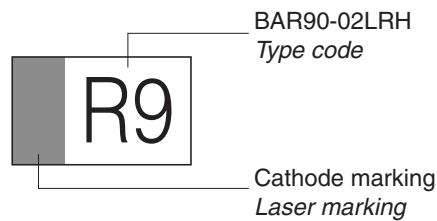

Standard Packing

Reel ø180 mm = 15.000 Pieces/Reel
 Reel ø330 mm = 50.000 Pieces/Reel (optional)

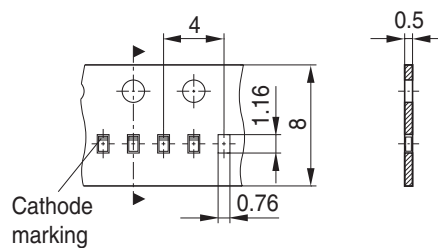

Package Outline

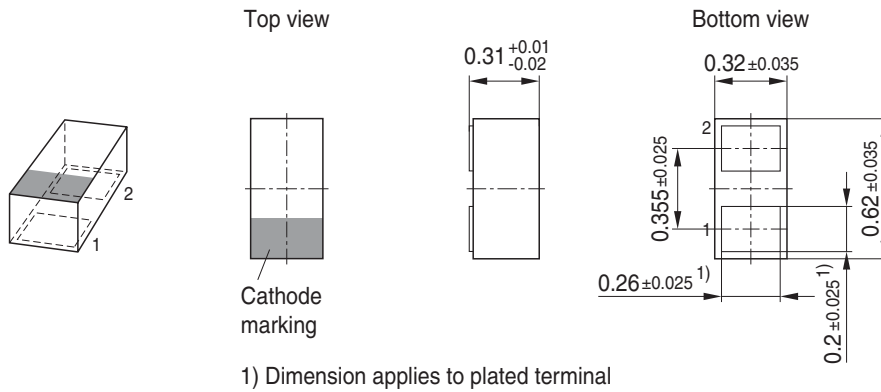

Foot Print

For board assembly information please refer to Infineon website "Packages"

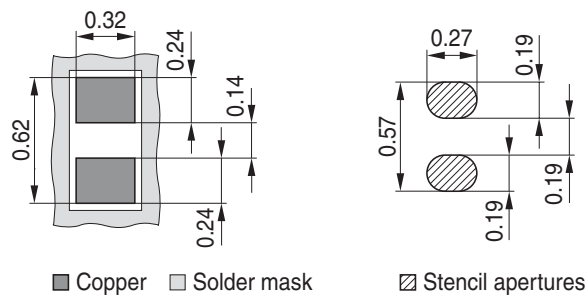

Marking Layout

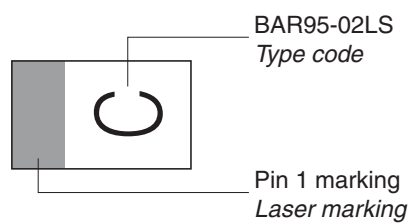

Standard Packing

Reel ø180 mm = 15.000 Pieces/Reel

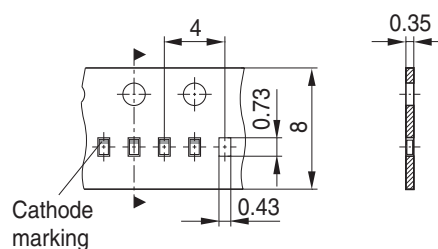

Edition 2006-02-01

Published by

Infineon Technologies AG

81726 München, Germany

© Infineon Technologies AG 2007.

All Rights Reserved.

Attention please!

The information given in this dokument shall in no event be regarded as a guarantee of conditions or characteristics ("Beschaffenheitsgarantie"). With respect to any examples or hints given herein, any typical values stated herein and/or any information regarding the application of the device, Infineon Technologies hereby disclaims any and all warranties and liabilities of any kind, including without limitation warranties of non-infringement of intellectual property rights of any third party.

Information

For further information on technology, delivery terms and conditions and prices please contact your nearest Infineon Technologies Office (www.infineon.com).

Warnings

Due to technical requirements components may contain dangerous substances. For information on the types in question please contact your nearest Infineon Technologies Office.

Infineon Technologies Components may only be used in life-support devices or systems with the express written approval of Infineon Technologies, if a failure of such components can reasonably be expected to cause the failure of that life-support device or system, or to affect the safety or effectiveness of that device or system.

Life support devices or systems are intended to be implanted in the human body, or to support and/or maintain and sustain and/or protect human life. If they fail, it is reasonable to assume that the health of the user or other persons may be endangered.